

MP6C

6 CYL. INJECTION CONTROL UNIT OBD INSTALLATION MANUAL



- LONTANO da possibili **INFILTRAZIONI D'ACQUA**.
- FAR from any **WATER LEAKAGE**



- LONTANO da **ECESSIVE FONTI DI CALORE** (esempio collettori di scarico).
- FAR from **EXCESSIVE HEAT SOURCES** (such as exhaust manifolds).



- LONTANO dai **CAVI DELL'ALTA TENSIONE**.
- FAR from **HIGH-VOLTAGE CABLES**.



Fare delle buone connessioni elettriche evitando l'uso dei "RUBACORRENTE".
Si tenga presente che la migliore connessione elettrica è la saldatura debitamente isolata.

Create efficient electrical connections without using any "POWER TAPS".
Properly insulated soldering is the most effective type of electrical connection.



Avvisare il cliente che in caso di rottura del fusibile dell'impianto a GAS, il Sistema ripristina i collegamenti dei dispositivi a cui è collegato. Si sconsiglia vivamente di sostituire il fusibile con un'altro di amperaggio maggiore, cio' puo' provocare danni irreparabili.

Advise the customer that if the GAS system fuse burns, the connections of the devices to which it is connected will be restored. It is strongly recommended not to replace the fuse with another one with a higher amperage rating since it may cause irreparable damage.



Non aprire per nessun motivo la scatola della Centralina soprattutto con il motore in moto o il quadro inserito, onde evitare danni irreparabili.

Si declina ogni responsabilità per danni a cose e persone derivati dalla manomissione del proprio dispositivo da parte di personale non autorizzato con la conseguente perdita di GARANZIA.

Do not open the Control Unit box for any reason, especially when the engine is running or the key is in the ignition, to avoid irreparable damage.

Will not be held responsible for damage to property or injuries to persons if unauthorised

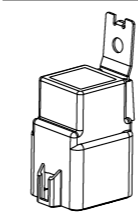

L'architettura dal sistema prevede l'utilizzo di un Relay esterno. Se non presente sul cablaggio o in caso di sostituzione utilizzarne uno con le seguenti caratteristiche: 12V, 30A, contatto N.A.

The architecture of the system includes the use of an external relay. If not present in the wiring or in the case of replacement use one with the following features: 12V, 30A, N.A. contact.

Specifiche tecniche / Technical specifications

Tensione di alimentazione / Supply voltage	Vbatt=10÷16V
Temperatura di funzionamento / Operating temperature	-40÷110°C
Fusibile di protezione / Protection fuse	MAX 15A
Assorbimento di corrente con attuatori disattivi / Current absorption with the actuators disabled	Imax ≤0.5A
Assorbimento di corrente in modalità standby / Current absorption in standby mode	Istandby ≤10 µA
Attuatori gestiti / Actuators managed	Fino a 6 iniettori con caratteristiche: Imax= 6A, Vbat max= 16V
	up to 6 injectors with the following characteristics: Imax=6A, Vbat max=16V
Uscita fili elettrovalvole gas / Wire output gas solenoid valves	Pmax=25W, Imax=2A (potenza e corrente massima per ogni uscita con due uscite attive)
	Pmax=50W, Imax=4A (potenza e corrente massima con solo una uscita attiva)
	Pmax=25W, Imax=2A (power and maximum current for each output with two outputs enabled)
	Pmax=50W, Imax=4A (power and maximum current with just one output enabled)

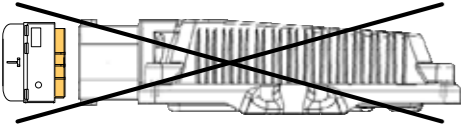
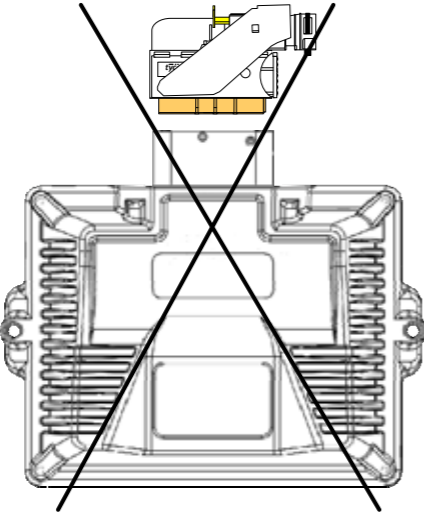
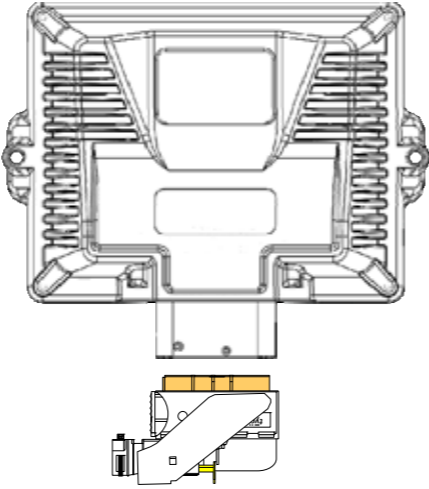
<p>INSTALLAZIONE ERRATA INCORRECT INSTALLATION</p>	<p>INSTALLAZIONE ERRATA INCORRECT INSTALLATION</p>	<p>INSTALLAZIONE CORRETTA CORRECT INSTALLATION</p>
		



ATTENZIONE
WARNING

Fissare il cablaggio della centralina in modo appropriato (per esempio tramite fascetta) ad un supporto nel vano motore per ridurre al minimo le vibrazioni trasmesse alla centralina

Fix the wiring control unit appropriately (for example with clamp) to a support in the engine compartment to reduce vibration transmitted to the ECU

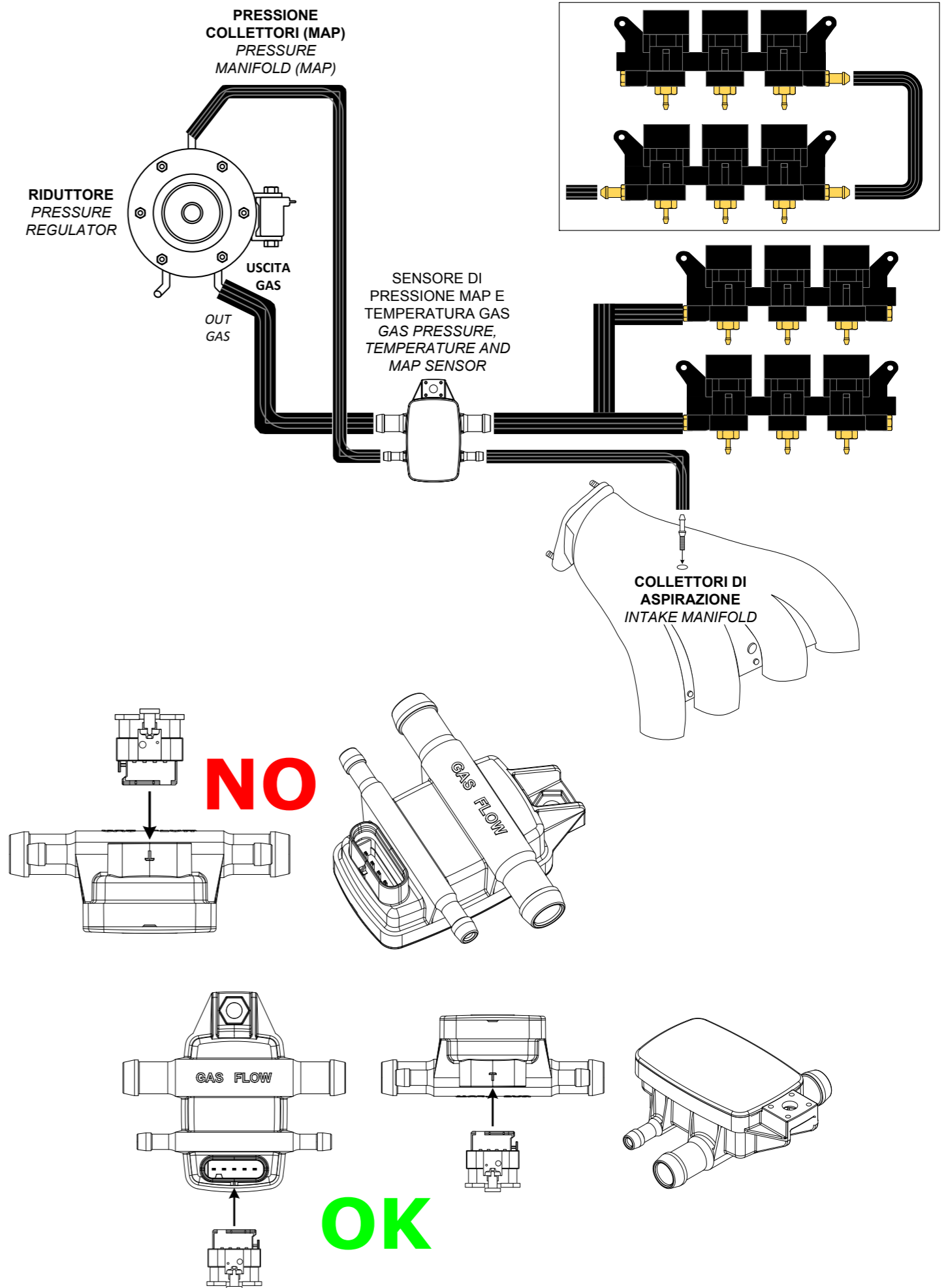
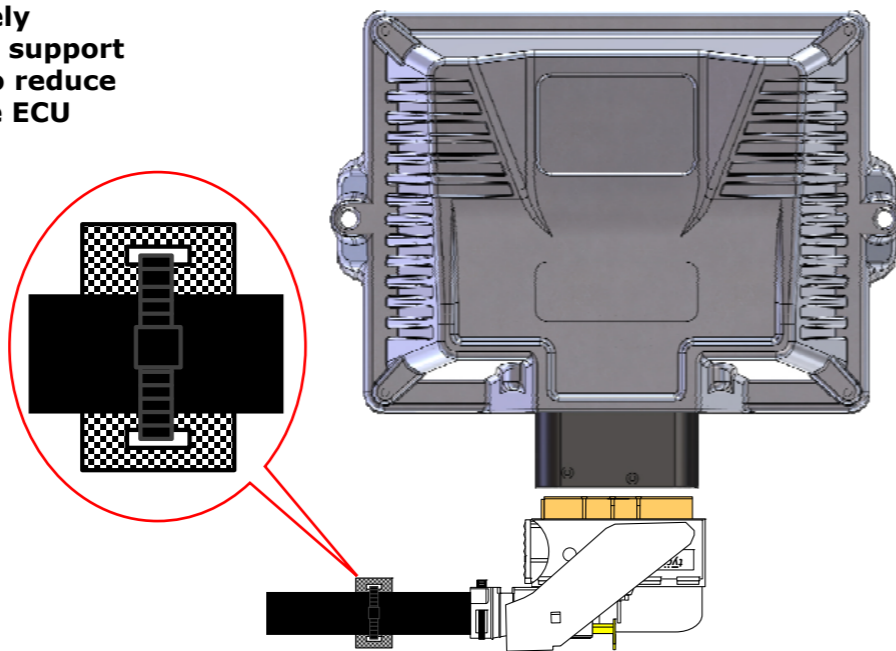

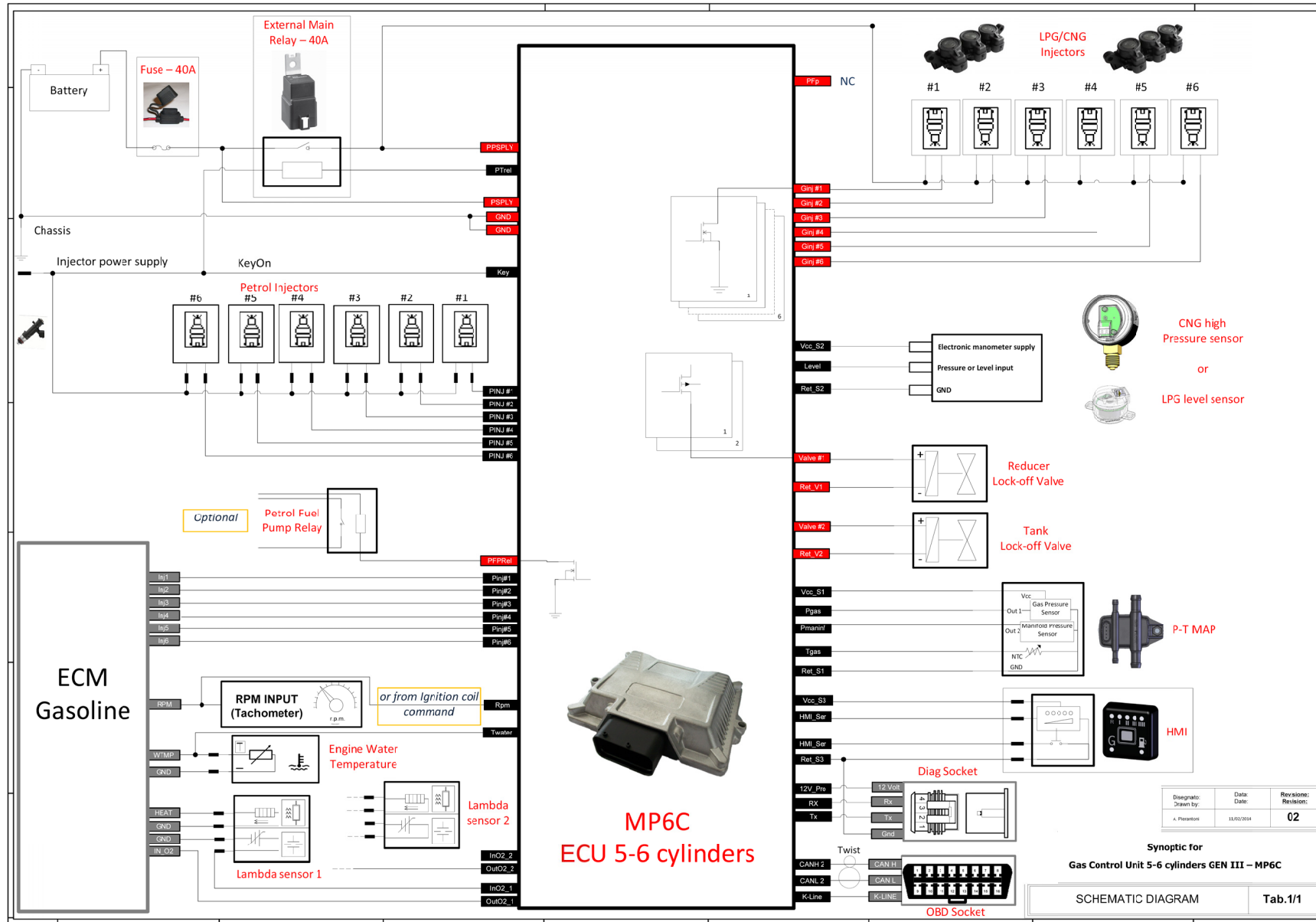

Designator:	Date:	Revision:
Drawn by:	18/02/2014	02
Approved:		

Synoptic for
Gas Control Unit 5-6 cylinders GEN III – MP6C

SCHMATIC DIAGRAM Tab.1/1

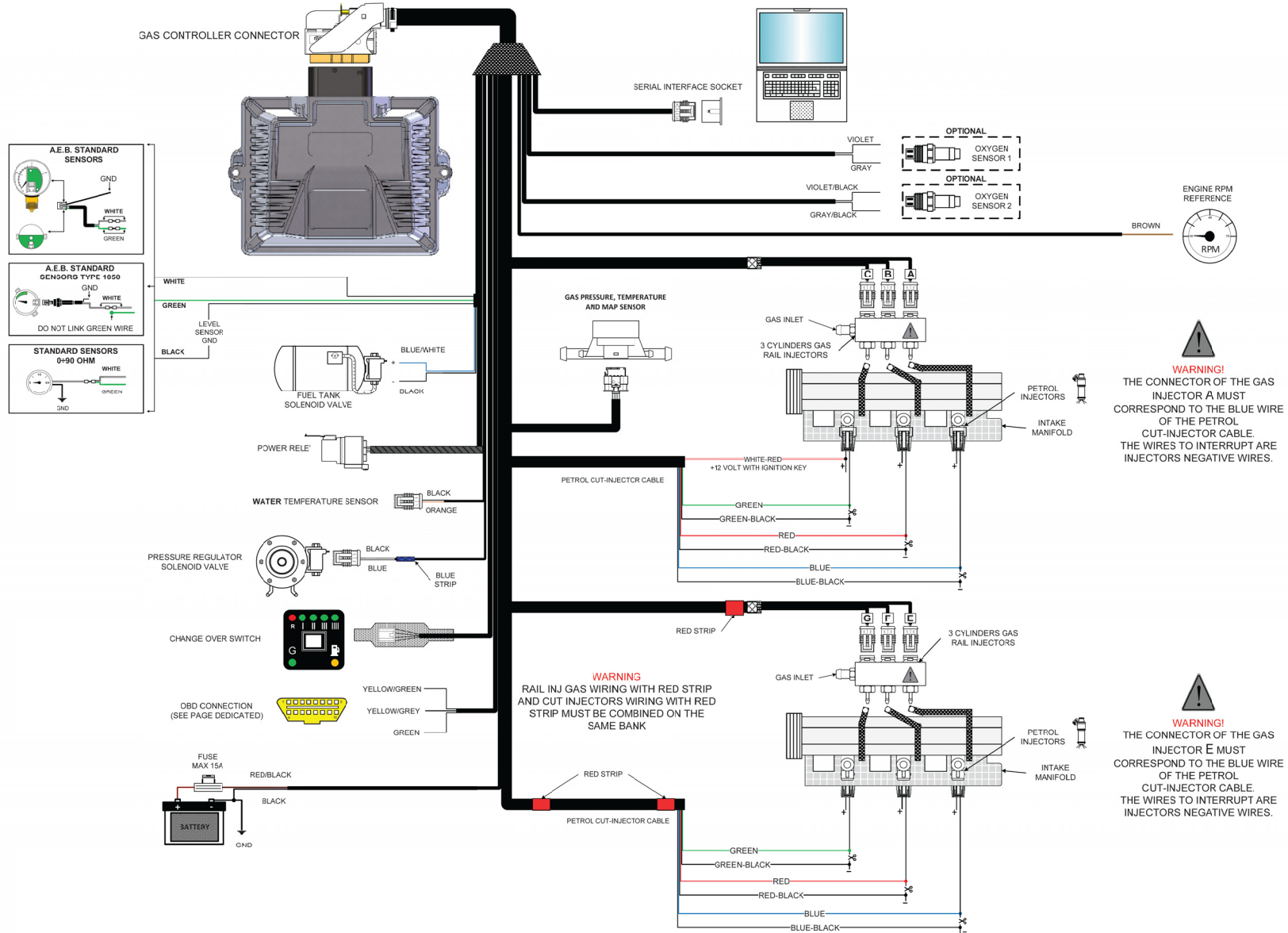

Description of the connections made on the OBD connector English

Through connection to the vehicle's OBD socket, this new generation of GAS control units makes it possible to acquire information useful for properly setting up the vehicle. Several carburetion parameters acquired from the PETROL control unit can be seen using the special software for connecting the GAS control unit to the PC, such as:

- Carburetion calibrators (Fast and Slow).
- Voltage on the rear lambda probe.

Connect a hand-held tester (CODE AEB214), and check the type of connection. If the tester reads connection types 1,2, or 3, proceed by following the diagram in figure 1. If the tester reads connection types 6,7,8 or 9, proceed by following the diagram in figure 2.

ATTENTION: If the tester (CODE AEB214) reads a type of connection that is not stated above, do not connect to any of the signals.

TYPE OF CONNECTION	CONNECTION DETAILS
Connection type 1	ISO 9141-2
Connection type 2	KWP-2000 Fast Init
Connection type 3	KWP-2000 Slow Init

OBD Connector seen frontal FIG.1

Connect the GREEN wire to the signal found on PIN 7 of the OBD connector.

ATTENTION: The YELLOW-GREEN and YELLOW-GREY wires must be isolated and not connected.

TYPE OF CONNECTION	CONNECTION DETAILS
Connection type 6	CAN Standard 250 Kbps
Connection type 7	CAN Extended 250 Kbps
Connection type 8	CAN Standard 500 Kbps
Connection type 9	CAN Extended 500 Kbps

OBD Connector seen frontal FIG.2

Connect the YELLOW-GREEN wire to the signal found on PIN 6 and the wire YELLOW-GREY to PIN 14 of the OBD connector.

ATTENTION: The GREEN wire must be isolated and not connected

Changeover switch operation English

Operating description

The changeover switch supplied with the kit has one button, 7 LEDs and an internal buzzer.

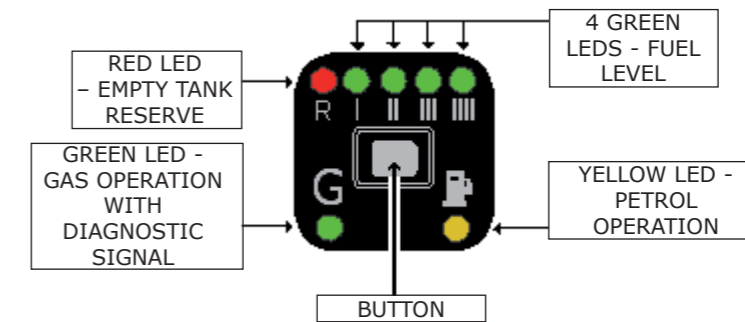

BUTTON

This is used to select either the petrol or the gas fuel supply. Press the button one time to switch to gas and press it again to return to petrol.

GREEN LED FUNCTIONS

Rapid flashing – the control unit is prepared to start with petrol and switch automatically to GAS.
Steady on with yellow LED off – Gas operation.

RED LED + 4 GREEN LED FUNCTIONS

Fuel level indicator; reserve RED LED, while the 4 GREEN LEDS indicate the fuel level (1/4, 2/4, 3/4, 4/4). The indicator is illuminated only when the gas mode is selected.

YELLOW LED FUNCTIONS

Steady on with Green LED off – PETROL operation.
Steady on with flashing Green LED – the control unit is prepared to start with petrol and switch automatically to Gas.

LOW GAS PRESSURE PETROL CHANGEOVER

When the changeover switch indicates the fuel tank is in **reserve** and the gas pressure drops below a set value, the control unit automatically switches over to gas. This prevents the engine from running with an excessively lean carburetion, thus damaging the catalyser. Before returning to gas operation, fill up. The changeover switch signals the **changeover to petrol due to low gas pressure** by activating the internal buzzer, illuminating the YELLOW petrol operation LED and by illuminating the RED LED in an alternating pattern with the 4 GREEN LEDS. To make the changeover switch return to normal operation press the BUTTON one time; the YELLOW LED will remain on to indicate that the car is operating with petrol and the buzzer turns off.

DIAGNOSTIC ERROR FINDING

The switch reports a finding of a diagnostic error by turning on the YELLOW fuel operation LED, by making the GREEN GAS LED blink rapidly and by sounding a warning with the internal buzzer. To put the switch back into normal operation, press the BUTTON once. The YELLOW LED will stay on to indicate the vehicle is operating with fuel and the buzzer will turn off.

EMERGENCY

If the car won't start with petrol (e.g. problems with the petrol pump, etc.), it can be started directly with GAS. To do this follow the instructions listed below:

- insert the ignition key and press the button to switch the changeover switch to gas operation;
- remove the key;
- insert the ignition key and keep pressing the button (about 5 seconds) until the GREEN LED stops flashing;
- now, start the engine without turning off the ignition key; the car will start directly with GAS;
- each time the car engine is turned off, the operation will have to be repeated to start in the EMERGENCY condition.

WARNING!

The EMERGENCY function can be activated only if the changeover switch is illuminated when the ignition key is turned

CUT INJECTOR WIRING DESCRIPTION

How to check what cut injector wiring to use

There are different types of cut injector wiring to match with the injection control unit.

NOTE: the cut injector wiring must be ordered separately since it is not included in the kit.

To know what type of cut injector wiring to use, you must first check, on the petrol injector connector, on what PIN the injector positive is connected.

To identify which of the two wires is positive, do the following:

- detach all the connectors from the injectors;
- set a multimeter to measure DC voltage;
- put the negative probe to ground;
- put the positive probe into one of the two pins of the injector wiring;
- insert the key into the ignition and immediately check the multimeter reading.

If the multimeter reads +12 volts, that pin is the positive.

WARNING: the injector +12 volt on some cars might be timed; therefore the reading might disappear a few seconds after the ignition is turned on. Check the polarity of all injector wiring connectors to make sure that they are all polarised in the same way.

EXAMPLES OF CONNECTORS MOST COMMONLY USED

SA144 - SA144INV for 4-8 cylinder cars (For 8 cyl. use 2 types of wiring).

Wiring types **SA144** and **SA144INV** are equipped with "BOSCH" type connectors to connect directly to the petrol injectors. To know whether to use model **SA144** or **SA144INV**, check the polarisation on the petrol injector wiring.

SA144: use this if the positive of the petrol injectors is on PIN A and the negative is on PIN B. Refer to figure 1.

SA144INV: use this if the positive of the petrol injectors is on PIN B and the negative is on PIN A. Refer to figure 1.

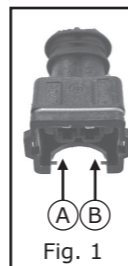

Fig. 1

SA144J - SA144JINV- SA144SJ for 4-8 cylinder cars (For 8 cyl. use 2 types of wiring).

Wiring types **SA144J** and **SA144JINV** are equipped with "JAPAN" type connectors to connect directly to the petrol injectors. To know whether to use model **SA144J** or **SA144JINV**, check the polarisation on the petrol injector wiring.

SA144J: use this if the positive of the petrol injectors is on PIN A and the negative is on PIN B. Refer to figure 2.

SA144JINV: use this if the positive of the petrol injectors is on PIN B and the negative is on PIN A. Refer to figure 2.

Wiring type **SA144SJ** is equipped with JAPAN type pins and extended wiring for installation on SUBARU cars with a BOXER engine. It is used **ONLY** if the positive of the petrol injectors is on PIN B and the negative is on PIN A. Refer to figure 2.

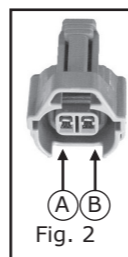

Fig. 2

SA144E

Wiring type **SA144E** is equipped with a single 6-pin connector. It can be used on some types of Fiat, Citroen or Peugeot cars that use the same connector on the injector wiring.

To install and to know on what cars it can be used, follow the instructions included with the wiring.

SA143 - SA143INV for 3 cylinder cars

Wiring types **SA143** and **SA143INV** are equipped with "BOSCH" type connectors to connect directly on the petrol injectors. To know whether to use model **SA143** or **SA143INV**, check the polarisation on the petrol injector wiring.

SA143: use this if the positive of the petrol injectors is on PIN A and the negative is on PIN B. Refer to figure 1.

SA143INV: use this if the positive of the petrol injectors is on PIN B and the negative is on PIN A. Refer to figure 1.

UNIVERSAL CUT INJECTOR WIRING DESCRIPTION

SA144U

All wires of the **SA144U** wiring are free and without connectors. This wiring is used on cars where other types of wiring cannot be installed or where it is impossible to access the injectors' original connectors.

To install this type of wiring, cut the negative wires of the petrol injectors in the order indicated in the figure. The connection direction is very important. The **BLACK striped** wires should be installed toward the petrol injection control unit and the others toward the injectors.

The **WHITE-RED** wire should be connected to any of the injector positives.

Connection diagram for 4-cylinder cars

WARNING!
Follow the sequence of connections. The **BLUE** and **BLUE-BLACK** wires must be positioned at the gas injector marked **A**. The others must be connected as indicated in the figure.

INTERRUPT THE INJECTOR NEGATIVE WIRES.

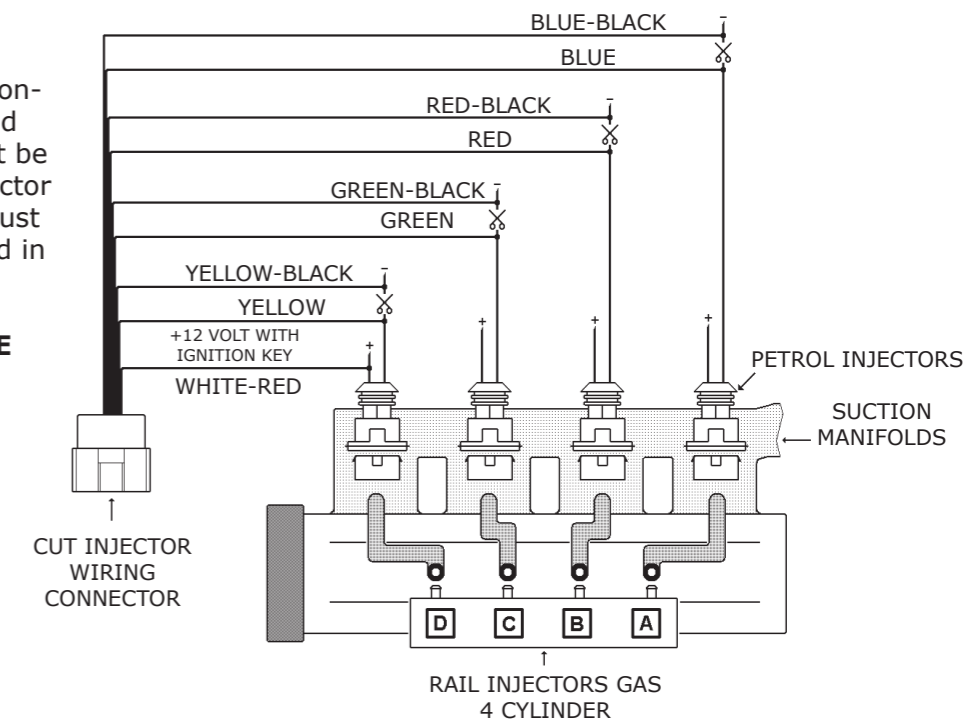

Connection diagram for 3-cylinder cars

WARNING!
For a connection on a 3-cylinder car the **YELLOW** and **YELLOW-BLACK** wires should remain disconnected. See the diagram.

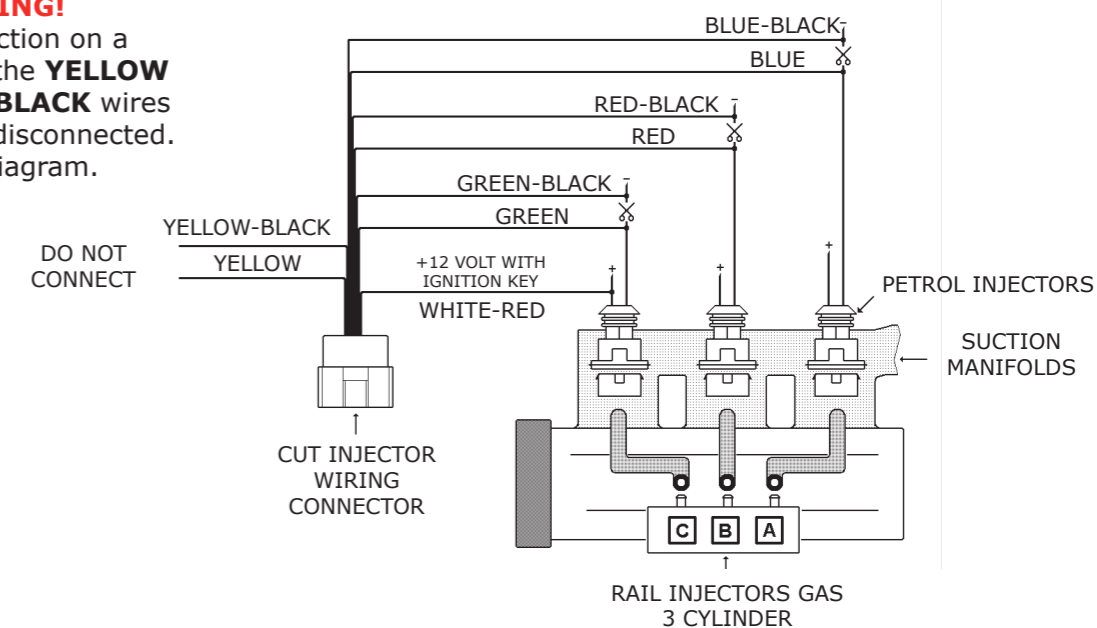

3 Homologation

ECU is homologated as per 10R-03, 67R-01 and 110R-00 norms

Homologation number:

- E3 10R-036333
- E3 67R-016019
- E3 110R-006039